

POLYSTEEL

6



CARROS DE
AUTOSERVICIO

CHARIOTS
AUTOSERVICES

SHOPPING
TROLLEY

Marsanz

SUMARIO SOMMAIRE SUMMARY

ACCESORIOS Y COMPLEMENTOS

ACCESSOIRES ET COMPLEMENTS

ACCESSORIES AND MISCELLANEOUS 4-5

GAMA STANDARD - GAMME STANDARD - STANDARD LINE

242 L STD 6

220 L STD - 195 L STD 7

160 L STD - 140 L STD (GRAN CARGA - GRANDE CHARGE - FOR CRATES) 8

160 L STD - 140 L STD 9

110 L STD - 90 L STD 10

ACCESORIOS STD - ACCESSOIRES STD - ACCESORIES STD 11

GAMA ANTIHURTO - GAMME SECURITE - ANTI-THEFT LINE

242 L ATH 12

220 L ATH - 195 L ATH 13

160 L ATH - 140 L ATH 14

110 L ATH - 90 L ATH 15

100 L. ATH - MULTIGRIP 16-17

ACCESORIOS ATH - ACCESSOIRES ATH - ACCESORIES ATH 18

GAMA "BGA" - GAMME "BGA" - "BGA" LINE

110 L TECNO-GARDEN - TECHNO-GARDEN 19

110 L TECNO-BRICOLAJE - TECHNO-D.I.Y. 19

90 L TECNO-GARDEN - TECHNO-GARDEN 20

90 L TECNO-GARDEN GRAN CARGA - HEAVY DUTY TECHNO-GARDEN 20

90 L TECNO-BRICOLAJE - TECHNO-D.I.Y. 21

90 L TECNO-BRICOLAJE GRAN CARGA - HEAVY DUTY TECHNO-D.I.Y. 21

ACCESORIOS BGA- ACCESSOIRES BGA - ACCESORIES BGA 22

CUBRE CARROS - ABRIS-CHARIOTS - TROLLEY SHELTERS 23

PARKING CARROS - ILOTS CHARIOTS - TROLLEY BAY 24

CERTIFICADO DE PRODUCTO - CERTIFICAT DE PRODUIT - PRODUCT CERTIFICATE 25

DIRECCIONES - ADRESSES - ADDRESS 26

CREACIONES MARSANZ, s.a. se reserva el derecho de modificación, sin previo aviso, de todo el producto expuesto en el presente catálogo. Asimismo, queda prohibida la reproducción total o parcial del mismo.

CREACIONES MARSANZ, s.a. se réserve le droit de modification, sans avis préalable, de tout produit exposé dans le présent catalogue, ainsi que la reproduction totale ou partielle du même.

CREACIONES MARSANZ, s.a. reserves the right to change any product from this catalogue without prior notice. Partial or full duplication of this catalogue is also prohibited.

POLYSTEEL

NUEVO ESTILO
NOUVEAU STYLE
NEW STYLE

AENOR



Producto
Certificado

A12 / 000003

UNE-EN 1929-1
UNE-EN 1929-2
UNE-EN 1929-3
UNE-EN 1929-4
UNE-EN 1929-7
UNE-EN 4892-2



NUEVO CONCEPTO
NOUVEAU CONCEPT
NEW CONCEPT



NUEVA IMAGEN
NOUVELLE IMAGE
NEW IMAGE



DURABILIDAD
DURABILITÉ
DURABILITY



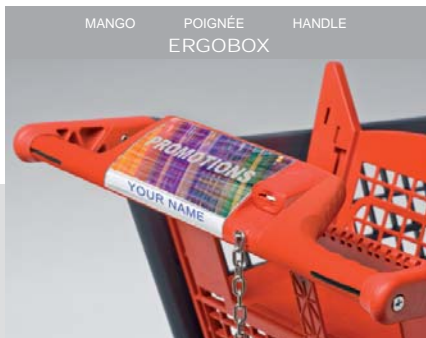

MANGO POIGNÉE HANDLE
ERGOBOX

Nuestro mango ERGOBOX de gran robustez ha sido el resultado de un minucioso estudio de ergonomía, consiguiendo con el diseño de su empuñadura un manejo mucho más cómodo del propio carro, con monedero integrado y ofreciendo un gran espacio para publicidad o para su marca.

Notre poignée ERGOBOX d'une grande solidité est le résultat d'une étude ergonomique minucieuse, obtenant avec la conception de sa poignée une maniabilité très confortable du chariot, avec consigneur intégré en offrant un grand espace pour la publicité ou pour votre personnalisation.

Our proven resistant ERGOBOX handle is the outcome of a meticulous study of ergonomics. Its handle design provides a comfortable use of the trolley. It comes with an integrated coin deposit system as well as with large advertising area.



PORTA-SCANNER
SUPPORT SCANNER
SCANNER HOLDER

Con el Porta-scanner (Motorola o Metrologic) y una lupa plegable para facilitar la difícil lectura de algunos productos hace de estos dos accesorios el mango perfecto y completo del mercado.

Avec le support scanner (Motorola ou Metrologic) et une loupe rabatable pour faciliter la difficile lecture de certains produits, pour que la poignée avec ces deux accessoires soit parfaite et la plus complète du marché.

LUPA PLEGABLE
LOUPE RABATABLE
MAGNIFYING GLASS

Our scanner holder (Motorola o Metrologic) and magnifying glass makes the most perfect and complete handle in the market.

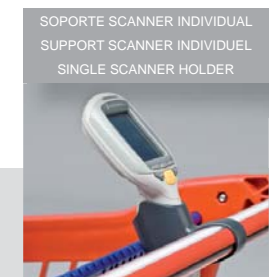

SOPORTE SCANNER INDIVIDUAL
SUPPORT SCANNER INDIVIDUEL
SINGLE SCANNER HOLDER

Sencillo soporte de scanner (Motorola-Metrologic), tanto para mango redondo como para mango ERGOGRIP

Support scanner simple (Motorola-Metrologic) pour poignée ronde ou ERGOGRIP .

Easy "use" scanner holder available (Motorola-Metrologic) for ERGOGRIP and round handle.



SOPORTE VASOS
SUPPORT Gobelets
CUP HOLDER

Sencillo soporte para vasos, integrado en nuestro mango ERGOBOX.

Support gobelets simple, intégré sur poignée ERGOBOX.

Integrated cup holder for Marsanz ERGOBOX handle



PROMOBOX

La manera más simple de darle mayor espacio publicitario, tanto para el mango Ergogrip (oval) como para el redondo.

Une solution simple pour avoir plus d'espace publicitaire, pour poignée Ergogrip (ovale) ou ronde.

The simplest way to maximise the advertisement area. Available for Ergogrip and round handle.



MANGOS DE FORMA REDONDA Y OVAL (ERGOGRIP)
POIGNÉES EN TUBE ROND ET OVAL (ERGOGRIP)
ROUND HANDLE AND ERGOGRIP OVAL HANDLE



ERGOBOX SIN MONEDERO
ERGOBOX SANS CONSIGNEUR
ERGOBOX WITHOUT LOCK



MODEDEROS CONSIGNEUR
SMARLOC

Plástico de alta calidad
Plastique haute qualité
High quality plastic



HANDLES AND COIN DEPOSIT SYSTEM
VARILOC

Acabado metálico
Finition métallique
Metal Finishing



REJILLA PLATAFORMA
GRILLE INFÉRIEURE
GRILL BASE



Solución para el aprovechamiento de carga de la plataforma standard. La inclinación de la parrilla facilita la encajabilidad del producto, al mismo tiempo que permite su uso en rampas mecánicas.

Une solution pour profiter d'une meilleure capacité de charge du socle standard. L'inclinaison de la grille facilite la capacité de produits, permettant à même temps utilisation sur les rampes mécaniques.

Extra loading capacity for the standard line trolleys. Perfect trolley nesting accuracy.



BANDERA DE LOCALIZACION
DRAPEAU DE LOCALISATION
FLAG LOCATION



SEPARADOR DE CESTO
SÉPARATEUR DE PANIER
BASKET DIVIDER

Complemento del cesto que permite tanto la ubicación de productos embolsados como de elementos más delicados.

Accessoire pour le panier qui permet le placement de produits fragiles ou sélectionnés.

Convenient way to carry personal belongings or bag-packaged products. Easy to fit.



PORTACARTEL PUBLICITARIO
SUPPORT PUBLICITÉ
ADVERTISEMENT HOLDER

Una forma sencilla de incrementar la rentabilidad de su carro, así como un método muy directo de impacto publicitario.

Un système facile pour augmenter la rentabilité de votre chariot, ainsi qu'un support très direct pour l'impact publicitaire.

The effective way to increase the trolley profitability while attracting your customer's attention to your store promotions.

CESTO SOPORTE CUNA
CORBEILLE SUPPORT COQUE BÉBÉ
BASKET FOR BABY CRADLE



Perfecto complemento para cualquier tipo de cuna.

Complément parfait pour l'emploi de tout type de coque bébé.

The perfect complement for every type of cradle.

CUNA DE CESTO
COQUE BÉBÉ
BABY CRADLE



Su perfecto diseño así como los materiales empleados, hace de la cuna el asiento ideal para el bebé, sin llegar a restar capacidad de carga al propio carro.

Sa conception ainsi que les matériaux employés, font de la coque le siège idéal pour le bébé, sans réduction de la capacité du chariot.

Best place for babies thanks to perfect design and materials. Keeping same trolley capacity.

PORTA-BEBE DOBLE FUNCION
PORTE-BÉBÉ DOUBLE FONCTION
DOUBLE FUNCTION BABY SEAT



Gracias a la tapa inferior del asiento, permite una carga adicional de producto, ideal para productos delicados.

Le volet rabatable du siège, permet de gagner un espace additionnel donné pour les produits fragiles.

Get an extra loading place (specially to carry fragile products) by folding up the plastic baby seat.

PORTA-BEBE DOBLE FUNCION (90 L - 110L)
PORTE-BÉBÉ DOUBLE FONCTION (90 L - 110L)
DOUBLE FUNCTION BABY SEAT (90 L - 110L)



RACK BOTELLERO PLEGABLE
CASIER PACK BOISSONS RABATABLE
BOTTLE RACK



Fácil de abatir, es el accesorio idóneo para transportar las cajas de líquidos o botelleros.

Facilement rabatable, c'est l'accessoire parfait pour le transport des packs de boissons.

It has been developed to carry bottle crates or big volume packages without reducing the basket loading capacity. The bottle rack will fold up when the trolley is nested.

RACK BOTELLERO PLEGABLE (90 L - 110L)
CASIER PACK BOISSONS RABATABLE (90 L - 110L)
RACK BOTELLERO PLEGABLE (90 L - 110L)



RACK BOTELLERO DELANTERO
CASIER PACK BOISSON AVANT
FRONT BOTTLE RACK



Solución para el transporte de botelleros en los carros de 90L. y 110 L.

Solution pour le transport des packs boissons dans les chariots de 90L. et 110 L.

Front bottle rack solution for 90L. and 110 L.

GAMA DE COLORES
GAMME DE COULEURS
COLOUR RANGE



RAL 5002	AZUL ULTRAMARINO	BLUE OUTREMER	ULTRAMARINE BLUE
RAL 3000	ROJO FUEGO	ROUGE FEU	FLAME RED
RAL 6029	VERDE MENTA	VERT MENTHE	MINT GREEN
RAL 7015	GRIS PIZARRA	GRIS ARDOISE	SLATE GREY
RAL 1018	AMARILLO ZINC	JAUNE ZINC	ZINC YELLOW

POLYSTEEL 2 4 2 STD

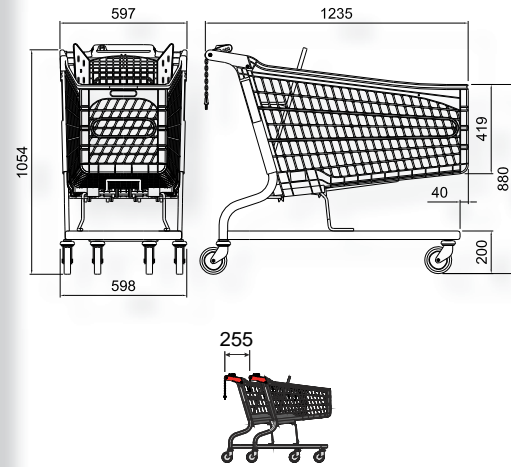

CPSDF24203
22,6kg.



CPSDF24206
22,9 kg.



CPSDF24208
22,6 kg.



POLYSTEEL 2 2 0 STD

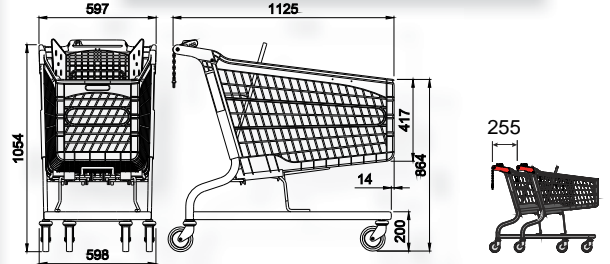

CPSDF22003
21,1 kg.



CPSDF22006
21,4 kg.



CPSDF22008
21,1 kg.

POLYSTEEL 1 9 5 STD

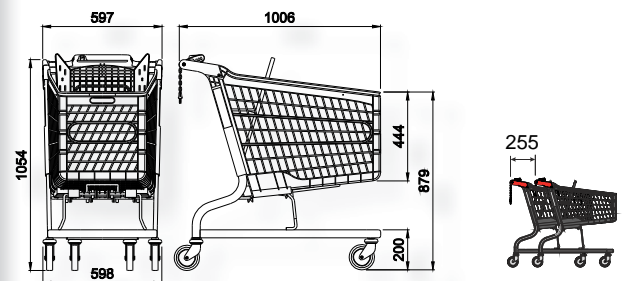

CPSDF19503
19,7 kg.



CPSDF19506
20 kg.



CPSDF19508
19,7 kg.

1 6 0 S T D GRAN CARGA - GRANDE CHARGE - FOR CRATES

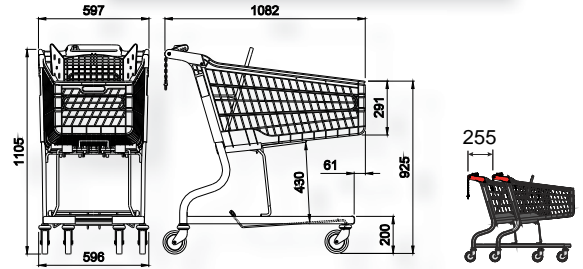

CPGDF 16003-RP
21,3 kg.



CPGDF 16006-RP
21,6 kg.



CPGDF 16008-RP
21,3 kg.

1 4 0 S T D GRAN CARGA - GRANDE CHARGE - FOR CRATES

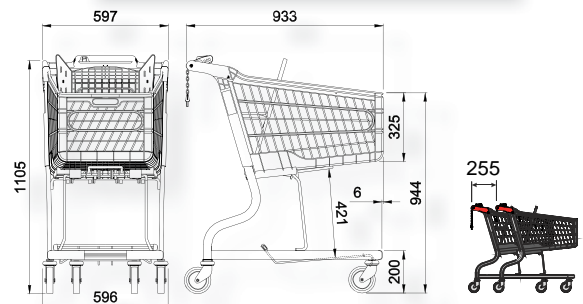

CPGDF 14003-RP
20,2 kg.



CPGDF 14006-RP
20,5 kg.



CPGDF 14008-RP
20,2 kg.

POLYSTEEL 1 6 0 STD

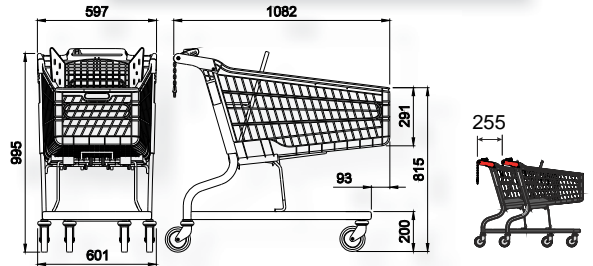

3



6



8

CPSDF16003
18,9 kg.

CPSDF16006
19,2 kg.

CPSDF16008
18,9 kg.

POLYSTEEL 1 4 0 STD

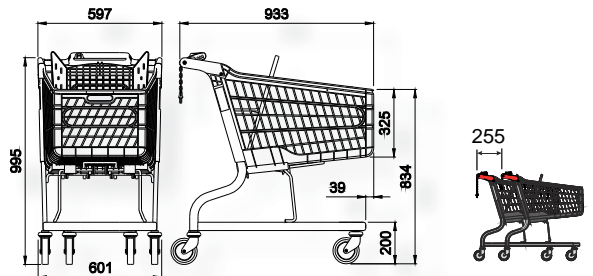

3



6



8

CPSDF14003
18,1 kg.

CPSDF14006
18,4 kg.

CPSDF14008
18,1 kg.

POLYSTEEL 1 1 0 STD

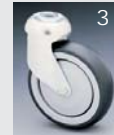
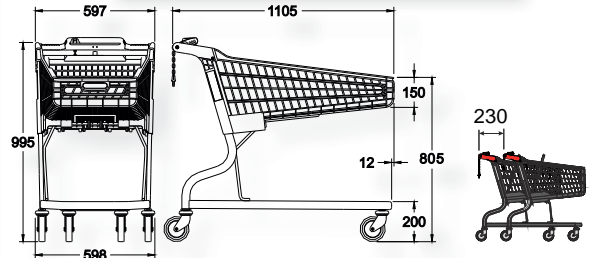

3

CPSSP11003
17,5 kg.



6

CPSSP11006
17,8 kg.



8

CPSSP11008
17,5 kg.

POLYSTEEL 9 0 STD

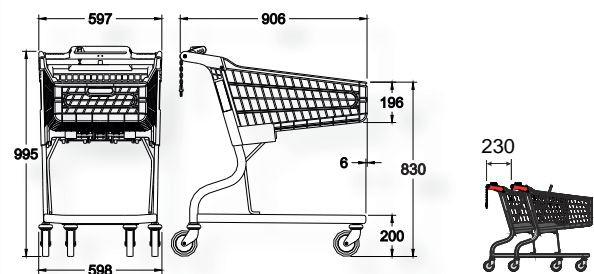

3

CPSSP09003
15,8 kg.















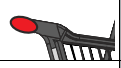

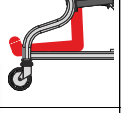

6

CPSSP09006
16,1 kg.



8

CPSSP09006
15,8 kg.

STANDARD			90	110	140	140 GC	160	160 GC	195	220	242
ACCESORIO ACCESSOIRE ACCESSORY											
	MANGO REDONDO POIGNEE RONDE ROUND HANDLE	CMRPS	●	●	●	●	●	●	●	●	●
	MANGO ERGOGRIP POIGNEE ERGOGRIP ERGOGRIP HANDLE	CMEFGPS	●	●	●	●	●	●	●	●	●
	SOPORTE SCANNER ERGOBOX SUPPORT SCANNER ERGOBOX ERGOBOX SCANNER SUPPORT SSE		●	●	●	●	●	●	●	●	●
	LUPA PLEGABLE LOUPE RABATABLE FOLDING MAGNIFYING GLASS LPMEBX		●	●	●	●	●	●	●	●	●
	SOPORTE SCANNER INDIVIDUAL SUPPORT SCANNER INDIVIDUEL SCANNER SUPPORT INDIVIDUAL SSIND		●	●	●	●	●	●	●	●	●
	SOPORTE VASOS SUPPORT GOBELETS CUP HOLDER SVMEBX		●	●	●	●	●	●	●	●	●
	PROMOBOX MANGO REDONDO PROMOBOX TUBE ROND PROMOBOX ROUND HANDLE PMR		●	●	●	●	●	●	●	●	●
	PROMOBOX MANGO ERGOGRIP PROMOBOX POIGNEE ERGOGRIP PROMOBOX ERGOGRIP HANDLE PMSEFG		●	●	●	●	●	●	●	●	●
	RACK BOTELLERO CASIER PACK BOISSONS BOTTLE RACK RBPS (140L- 242L) RBPF9011 (90L- 110L)		●	●	●	●	●	●	●	●	●
	BANDERA DE LOCALIZACION DRAPEAU DE LOCALISATION FLAG LOCATION MBCP		●	●	●	●	●	●	●	●	●
	PORTABEBE DOBLE FUNCION PORTE-BÉBÉ DOUBLE FONCTION DOUBLE FUNCTION BABY SEAT 9011RBDFPS (90L- 110L)		●	●	●	●	●	●	●	●	●
	REJILLA PLATAFORMA GRILLE INFÉRIEURE GRILL BASE RPLPS (140L) RGLPS (160L- 195L) RPLPS220 (220L) RPLPS242 (242L) RPPS110 (110L) RPPS90 (90L)		●	●	●	●	●	●	●	●	●
	REJILLA PLATAFORMA CORTA GRILLE INFÉRIEURE COURTE GRILL BASE WHEN BOTTLE RACK RPCPS (140L) RCGCS (160L-195L) RPCPS220 (220L)		●	●	●	●	●	●	●	●	●
	SEPARADOR DE CESTO SÉPARATEUR DE PANIER BASKET DIVIDER SPS14 SPS16 SPS19 SPS22 SPS24		●	●	●	●	●	●	●	●	●
	CUNA DE CESTO COQUE BÉBÉ BABY CRADLE CCBD		●	●	●	●	●	●	●	●	●
	CESTO SOPORTE CUNA CORBEILLE SUPPORT COQUE BÉBÉ BASKET FOR BABY CRADLE CSCP		●	●	●	●	●	●	●	●	●
	PORTACARTELES PUBLICITARIO SUPPORT PUBLICITÉ ADVERTISEMENT HOLDER PCPCP		●	●	●	●	●	●	●	●	●

STANDARD LINE

GAMME STANDARD

GAMA STANDARD

ACCESSOIRES ACCESSORIES

POLYSTEEL 2 4 2 ATH

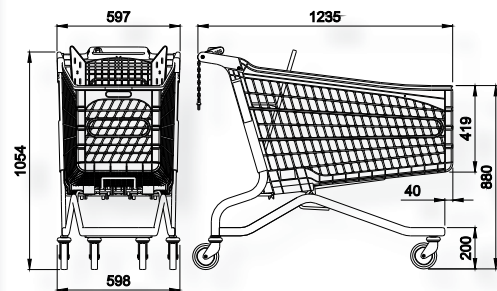

CPADF24203
22,7 kg.



CPADF24206
23 kg.



CPADF24208
22,7 kg.



POLYETEEL 2 2 0 ATH

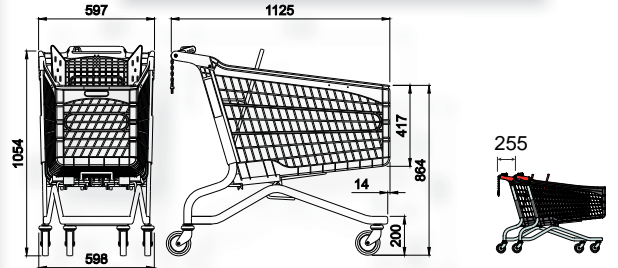

3

CPADF22003
21,2 kg.



6

CPADF22006
21,5 kg.



8

CPADF22008
21,2 kg.

POLYSTEEL 1 9 5 ATH

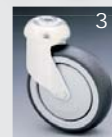
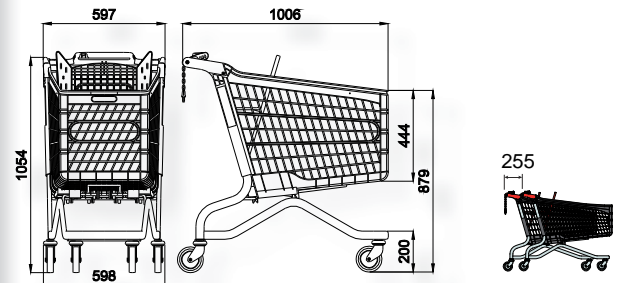

3

CPADF19503
19,5 kg.



6

CPADF19506
19,8 kg.



8

CPADF19508
19,5 kg.

POLYSTEEL 1 6 0 ATH

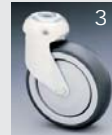
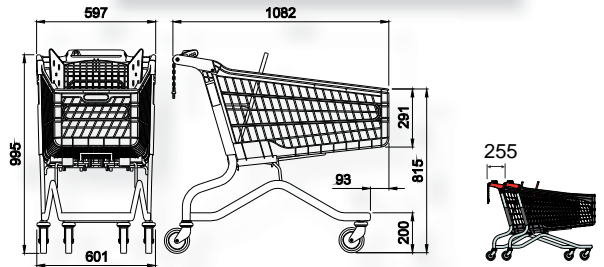

3

CPADF16003
18,9 kg.



6

CPADF16006
19,2 kg.



8

CPADF16008
18,9 kg.

POLYSTEEL 1 4 0 ATH

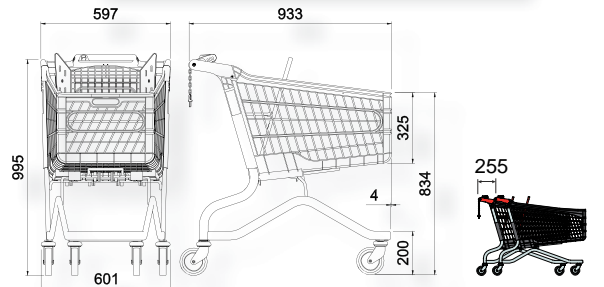

3

CPADF14003
18,2 kg.



6

CPADF14006
18,5 kg.



8

CPADF14008
18,2 kg.

POLYSTEEL 1 1 0 ATH

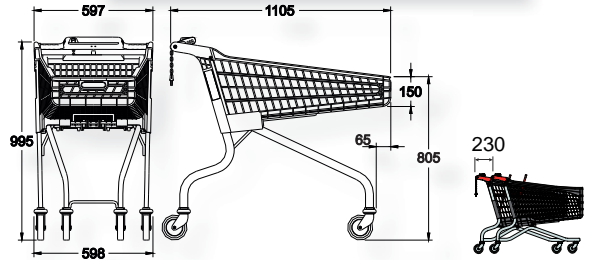

CPASP11003
16,4 kg.



CPASP11006
16,7 kg.



CPASP11008
16,4 kg.

POLYSTEEL 9 0 ATH

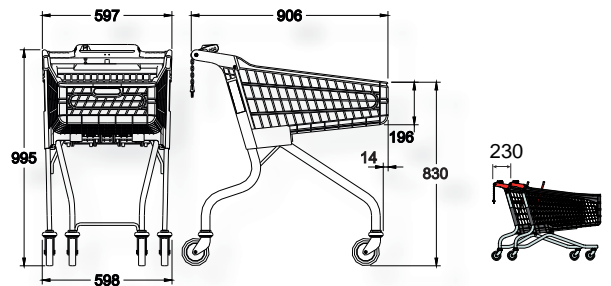

CPASP9003
14,9 kg.



CPASP9006
15,2 kg.



CPASP9008
14,9 kg.

POLYSTEEL 100 ATH MULTIGRIP



2



CPMASP1002B-RB
13,4 KG

CPMASP1002B
12,5 KG

MDCM

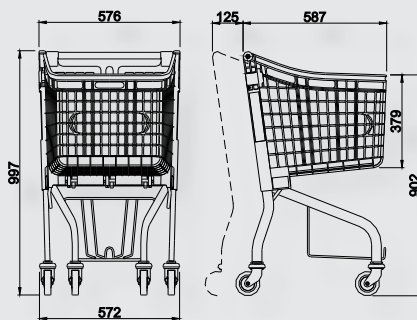

125 mm.



X 5	1,087 mts.
x 10	1,712 mts.
x 15	2,337 mts.
x 25	3,587 mts.



8



CPMASP1008-RB
14,1 KG

CPMASP1008
13,4 KG

MDCM

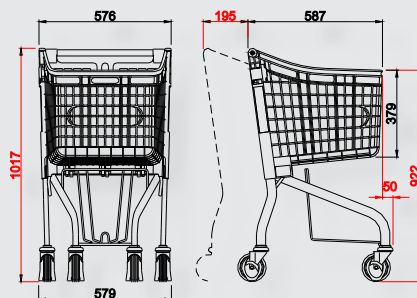

195 mm.



X 5	1,417 mts.
x 10	2,392 mts.
x 15	3,367 mts.
x 25	5,317 mts.

RAL 5002

RAL 3000

RAL 6029

RAL 7015

RAL 1018



MULTIPLES ZONAS DE AGARRE

MULTIPLE HANDLING

ANSE PÉRIMÉTRALE

360°

PERIMETRISCHER GRIFF



Su cesta de plástico asegura un menor número de desperfectos dentro y fuera del establecimiento.

- Sólido. Su diseño híbrido obtiene como resultado una gran fortaleza.
- Ligero. Su tamaño reducido y sus componentes plásticos facilitan su manejo.
- Silencioso. Este carro tan compacto, junto a la combinación del material plástico con el chasis metálico, tiene un índice de ruido muy bajo.
- Estable y seguro. El diseño de su chasis hace posible el manejo tanto en superficies llanas como en superficies de rampa, sean mecánicas o no.

Key Highlights

- **Strong, reliable and resistant to crashes**, due to its high quality materials and its flat oval tubing **chassis. Suitable for plain or traveller surfaces.**
- **Light, compact and easy to carry** (360 degrees movements allowed) thanks to its perimetral handle and 4 swivel wheels.
- **Silent:** This trolley has a very low noise rate thanks to its structure and light materials composition.
- **Comfortable to load/unload.** "Bye bye" to the extra efforts needed when unloading a wheeled basket at the check-out!
- **Bigger capacity than a wheeled basket**, thanks to its 100L capacity plus its bottle rack.
- **Customization.** Wide range of RAL colours as well as a customized handle.
- **Perfect for daily shopping.**
- Coin lock as an option, what enables to **stock the Multigrips both inside the shop as well as in the parking area.**













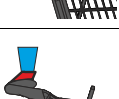

Sa **poignée** plus son accessibilité sur les: **3 côtés** du panier font du chariot Multi-grip de: 100l le chariot le plus **maniable** et le plus **confortable** du marché.

- **Rotation** possible sur: **360°**
- Une **contenance plus grande** que n'importe quel panier à roulettes
- **Un +:** Un **support packs** inclus dans la version standard
- **Consigner** possible en option soit un **stockage possible à l'extérieur** du magasin dans les abris à chariots
- Large **gamme de couleurs** offerte: Panier, Battant et Poignée peuvent s'harmoniser aux couleurs de **vostra enseigne**
- Faible encombrement - **Idéal pour les allées étroites** et pour les achats journaliers.
- Un nouveau **service** à offrir à vos clients.

Große Stärken:

- Ausgestattet mit einem perimetrischen Griff, was macht den Wagen handlich und zugänglich von allen Seiten.
- Bequeme Einkäufe: Die optimierte Ergonomie sowie die gute Stabilität des Wagens ermöglichen den Kunden eine einfache und bequeme Einkaufserfahrung.
- Mehr Kapazität als die Einkaufskörbe mit Rollen: 100L Korb + 32L Kistenablage.
- Ausgezeichnete Qualität: Gleiche Top-Qualität als unsere Hybrid Einkaufswagen (POLYSTEEL).
- Fest, stabil, leise und sicher.
- Perfekt für den täglichen Einkauf.
- Teil Ihres „Corporate Images“: Personalisiert mit einer vielfalte Kombination von RAL Farben und mit Ihrem Logo.



STANDARD		90	100 MULTIGRIP	110	140	160	195	220	242
	MANGO REDONDO POIGNÉE RONDE ROUND HANDLE CMRPS	●	●						
	MANGO ERGOGRIP POIGNÉE ERGOGRIP ERGOGRIP HANDLE CMEFGPS	●	—	●	●	●	●	●	●
	SOPORTE SCANNER ERGOBOX SUPPORT SCANNER ERGOBOX ERGOBOX SCANNER SUPPORT SSE	●		●	●	●	●	●	●
	LUPA PLEGABLE LOUPE RABATABLE FOLDING MAGNIFYING GLASS LPMEBX	●		●	●	●	●	●	●
	SOPORTE SCANNER INDIVIDUAL SUPPORT SCANNER INDIVIDUEL SCANNER SUPPORT INDIVIDUAL SSIND	●		●	●	●	●	●	●
	SOPORTE VASOS SUPPORT Gobelets CUP HOLDER SVMEXB	●		●	●	●	●	●	●
	PROMOBOX MANGO REDONDO PROMOBOX TUBE ROND PROMOBOX ROUND HANDLE PMR	●		●	●	●	●	●	●
	PROMOBOX MANGO ERGOGRIP PROMOBOX POIGNÉE ERGOGRIP PROMOBOX ERGOGRIP HANDLE PMSEFG	●		●	●	●	●	●	●
	RACK BOTELLERO CASIER PACK BOISSONS BOTTLE RACK RBPS (140L- 160L) RBPAP (195 L- 220L- 242L)				●	●	●	●	●
	RACK BOTELLERO DELANTERO CASIER PACK BOISSONS AVANT FRONT BOTTLE RACK RBFDP A90 RBFDP A110	●	●	●					
	BANDERA DE LOCALIZACION DRAPEAU DE LOCALISATION FLAG LOCATION MBCP	●		●	●	●	●	●	●
	PORTABEBÉ DOBLE FUNCION PORTE-BÉBÉ DOUBLE FONCTION DOUBLE FUNCTION BABY SEAT 9011RBDFPS (90L- 110L)	●		●					
	SEPARADOR DE CESTO SÉPARATEUR DE PANIER BASKET DIVIDER SPS14 SPS16 SPS19 SPS22 SPS24				●	●	●	●	●
	CUNA DE CESTO COQUE BÉBÉ BABY CRADLE CCBD	●		●	●	●	●	●	●
	CESTO SOPORTE CUNA CORBEILLE SUPPORT COQUE BÉBÉ BASKET FOR BABY CRADLE CSCP	●		●	●	●	●	●	●
	PORTACARTELES PUBLICITARIO SUPPORT PUBLICITÉ ADVERTISEMENT HOLDER PCPCP				●	●	●	●	●

1 1 0

TECNO-GARDEN

TECHNO-GARDEN

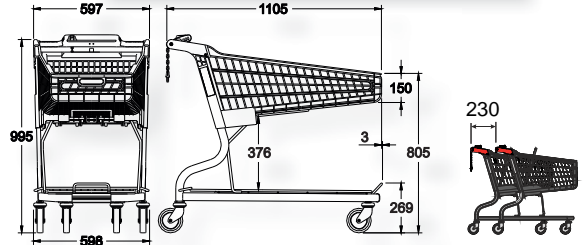

CPGSP11003
22,9 kg.



CPGSP11006
23,2 kg.



CPGSP11008
22,9 kg.

1 1 0

TECNO-BRICO LAJE

TECHNO-D.I.Y.

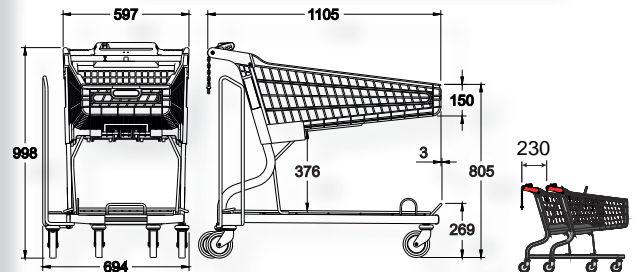

CPBSP11003
25,7 kg.



CPBSP11006
26 kg.



CPBSP11008
25,7 kg.

9 0

TECNO-GARDEN

TECHNO-GARDEN

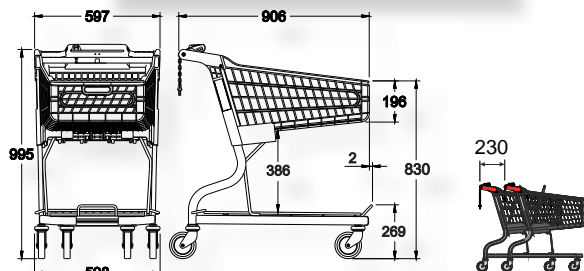

CPGSP09003
20,4 kg.



CPGSP09006
20,7 kg.



CPGSP09008
20,4 kg.

9 0

TECNO-GARDEN
GRAN CARGA

TECNO-GARDEN
GRANDE CHARGE

HEAVY DUTY
TECHNO-GARDEN

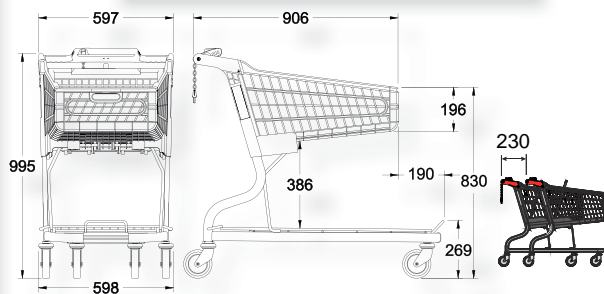

CPGGSP9003
22 kg.



CPGGSP9006
22,3 kg.



CPGGSP9008
22 kg.

9 0

TECNO-BRICO LAJE

TECHNO-D.I.Y.

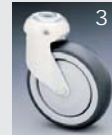
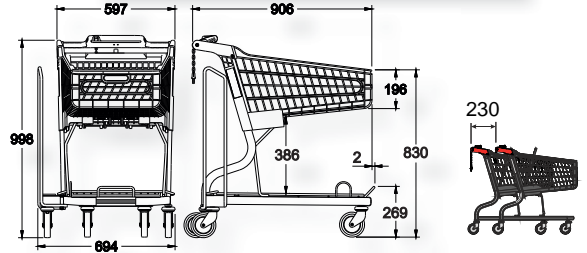

3



6



8

CPBSP09003
23,1 kg.

CPBSP09006
23,4 kg.

CPBSP09008
23,1 kg.

9 0

TECNO-BRICO LAJE
GRAN CARGA

TECHNO-D.I.Y.
GRANDE CHARGE

HEAVY DUTY
TECHNO-D.I.Y.

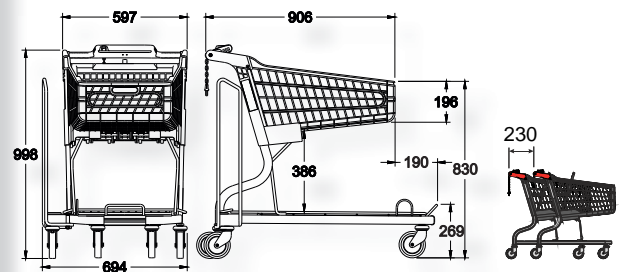

3



6















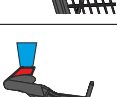

8

CPBGSP9003
24,7 kg.

CPBGSP9006
25 kg.

CPBGSP9008
24,7 kg.

STANDARD ACCESORIO ACCESSOIRE ACCESSORY		90 TG	90 TG GC	90 TB	90 TB GC	110 TG	110 TB
	MANGO REDONDO POIGNÉE RONDE ROUND HANDLE CMRPS	●	●	●	●	●	●
	MANGO ERGOGRIP POIGNÉE ERGOGRIP ERGOGRIP HANDLE CMEFGPS	●	●	●	●	●	●
	SOPORTE SCANNER ERGOWOX SUPPORT SCANNER ERGOWOX ERGOWOX SCANNER SUPPORT SSE	●	●	●	●	●	●
	LUPA PLEGABLE LOUPE RABATABLE FOLDING MAGNIFYING GLASS LPMEBX	●	●	●	●	●	●
	SOPORTE SCANNER INDIVIDUAL SUPPORT SCANNER INDIVIDUEL SCANNER SUPPORT INDIVIDUAL SSIND	●	●	●	●	●	●
	SOPORTE VASOS SUPPORT GOBELETS CUP HOLDER SVMEBX	●	●	●	●	●	●
	PROMOBOX MANGO REDONDO PROMOBOX TUBE ROND PROMOBOX ROUND HANDLE PMR	●	●	●	●	●	●
	PROMOBOX MANGO ERGOGRIP PROMOBOX POIGNÉE ERGOGRIP PROMOBOX ERGOGRIP HANDLE PMSEFG	●	●	●	●	●	●
	BANDERA DE LOCALIZACION DRAPEAU DE LOCALISATION FLAG LOCATION MBCP	●	●	●	●	●	●
	PORTABEBÉ DOBLE FUNCION PORTE-BÉBÉ DOUBLE FONCTION DOUBLE FUNCTION BABY SEAT 9011RBDFPS (90L - 110L)	●	●	●	●	●	●
	CUNA DE CESTO COQUE BÉBÉ BABY CRADLE CCBD	●	●	●	●	●	●
	CESTO SOPORTE CUNA CORBEILLE SUPPORT COQUE BÉBÉ BASKET FOR BABY CRADLE CSCP	●	●	●	●	●	●
	BANDEJA INFERIOR TECNO-GARDEN GRILLE INFÉRIEURE TECHNO GARDEN TRAY BASE FOR TECHNO-GARDEN 90TGP2 (90L) 110TGP2 (90L GC - 110L)	●	●			●	
	BANDEJA INFERIOR TECNO-BRICO LAJE GRILLE INFÉRIEURE TECHNO-D.I.Y. TRAY BASE FOR TECHNO-D.I.Y. 90TBP2 (90L) 110TBP2 (90L GC - 110L)			●	●		●
	PORTATABLEROS SUPPORT PANNEAUX SIDE RACK PTTO3			●	●		●



El parking es el primer contacto visual de su negocio con su cliente y exponente principal de su marca. Unos cobijos personalizados refuerzan el impacto de imagen de su tienda con respecto a su entorno. Consúltenos para realizaciones a su medida.



Le parking c'est le premier contact visuel de votre enseigne avec votre clientèle et principal exposant de votre marque. Des abris-chariots personnalisés renforcent l'impact de l'image de votre magasin vis à vis de son environnement. Consultez-nous pour des réalisations à votre mesure.

The trolleys shelter is the first contact of your business by the client, and the principal of your brand. These customized trolley shelters reinforce the image of your store according to its environment.



BARRA TOPE INFORMACION SIN GUIAS LATERALES

TÊTE D'ILOT AVEC INFORMATION, SANS GUIDES LATÉRAUX
 END INFORMATION BAR WITHOUT SIDE GUIDANCE BARS

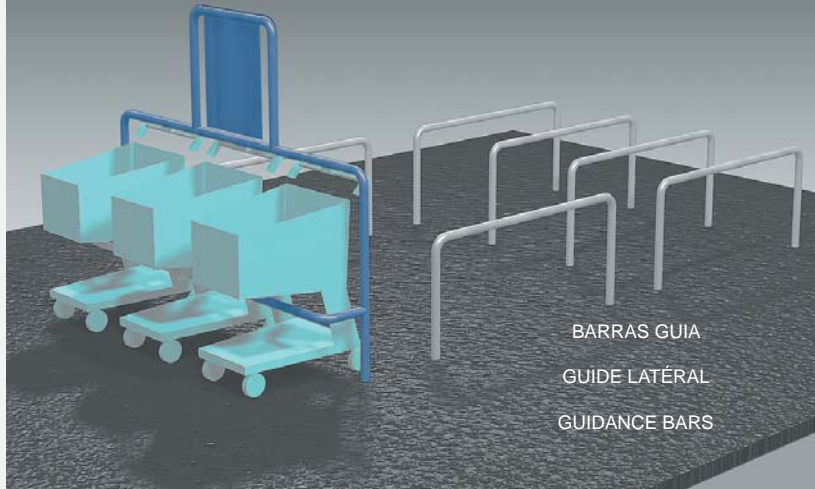

BARRAS GUIA
 GUIDE LATÉRAL
 GUIDANCE BARS

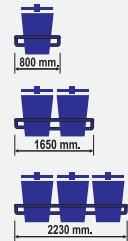
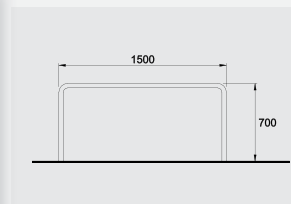
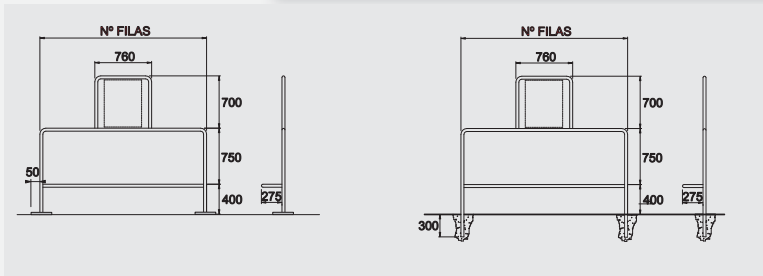

BARRA TOPE INFORMACION CON GUIAS LATERALES

TÊTE D'ILOT AVEC INFORMATION, AVEC GUIDES LATÉRAUX
 END INFORMATION BAR WITH SIDE GUIDANCE BARS

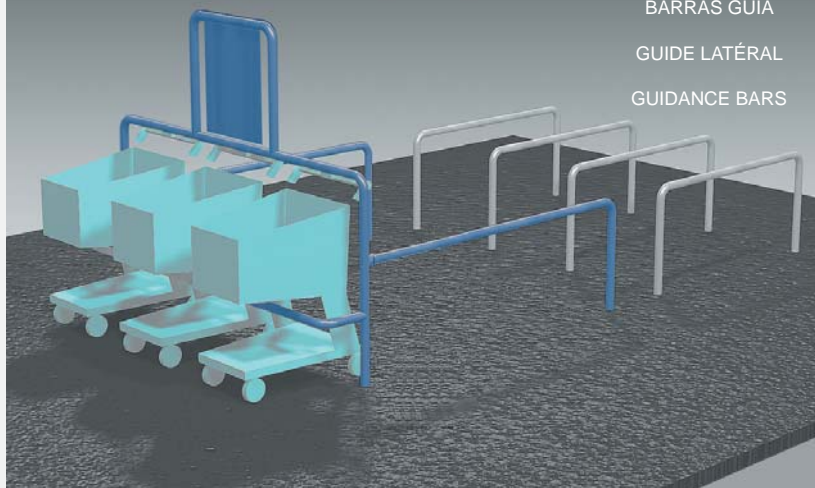

BARRAS GUIA
 GUIDE LATÉRAL
 GUIDANCE BARS

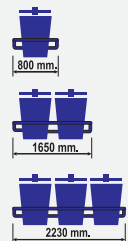
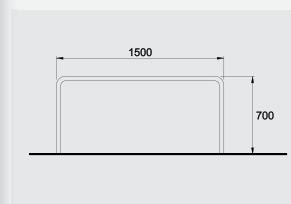
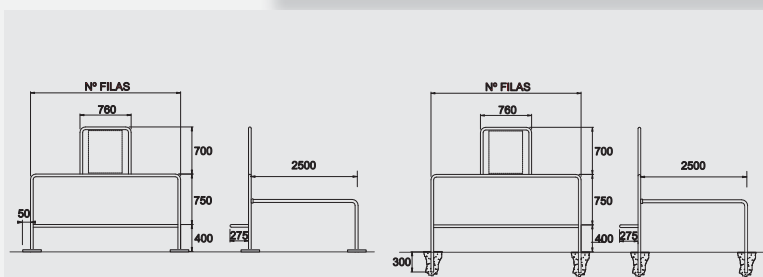



AENOR Asociación Española de
Normalización y Certificación

CERTIFICADO AENOR DE PRODUCTO N° A12 / 000003
AENOR PRODUCT CERTIFICATE N°

Pg. 1/6
2013-12-11

La Asociación Española de Normalización y Certificación (AENOR) certifica que el producto
The Spanish Association for Standardisation and Certification (AENOR) certifies that the product

**CARROS DE COMPRA DE PLÁSTICO PARA USUARIOS DE SUPERMERCADO E
HIPERMERCADO**

PLASTIC BASKET TROLLEYS FOR SUPERMARKET USERS

detallado en la(s) página(s) siguiente(s),

detailed in the following page(s),

suministrado por

supplied by

CREACIONES MARSANZ, S.A.

CL HIERRO, 27

28850 TORREJON DE ARDOZ (Madrid - España)

y elaborado en

and manufactured in

CL HIERRO, 27

28850 TORREJON DE ARDOZ (Madrid - España)

es conforme con

complies with

UNE-EN ISO 4892-2:2006/A1:2010 (EN ISO 4892-2:2006/A1:2009)

UNE-EN 1929-1:1998 (EN 1929-1:1998)

UNE-EN 1929-2:2005 (EN 1929-2:2004)

UNE-EN 1929-3:2005 (EN 1929-3:2005)

UNE-EN 1929-4:2005 (EN 1929-4:2005)

UNE-EN 1929-7:2005 (EN 1929-7:2005)

Para conceder este Certificado, AENOR ha ensayado el producto y ha comprobado el sistema de la calidad aplicado para su elaboración. AENOR realiza estas actividades periódicamente mientras el Certificado no haya sido anulado, según se establece en el Reglamento Particular RP A12.01.

In order to grant this Certificate, AENOR has tested the product and has verified the quality system used in its manufacture. AENOR performs these tasks periodically while the Certificate has not been cancelled, in accordance with the stipulations of the Specific Rules RP A12/01.

Fecha de concesión: **2013-12-11**
First issued on:

Fecha de caducidad: **2018-12-11**
Expires on:

AENOR Asociación Española de
Normalización y Certificación

Avelino BRITO/MARQUINA
Director General de AENOR/ Chief Executive Officer

No está autorizada la reproducción parcial de este documento.

The partial reproduction of this document is not permitted.

AENOR - Génova, 6 - 28004 MADRID - Teléfono 914 32 60 00 - Telefax 913 10 46 83

www.marsanz.es



SEDE SOCIAL
SIÈGE
HEAD OFFICE

CALLE HIERRO, 27
28850 TORREJON DE ARDOZ
MADRID
ESPAÑA - SPAIN

TEL.: (34) 91 675 14 34 // (34) 91 677 10 92
FAX.: (34) 91 675 12 90
E.MAIL.: creaciones@marsanz.es

PLANTAS DE FABRICACION
USINES
PRODUCTION FACILITIES

TORREJON DE ARDOZ (MADRID)
UGENA (TOLEDO)

INTERNACIONAL
INTERNATIONAL

EXPORT DIVISION

E.MAIL.: export@marsanz.es

FRANCIA
FRANCE

MARSANZ FRANCE SAS

13 RUE SAINT HONORÉ
78000 VERSAILLES

TEL.: +33 (0) 1 30 88 82 95
E.MAIL.: info@marsanz.fr
www.marsanz.fr

REINO UNIDO
UNITED KINGDOM

MARSANZ UK Ltd.

30 CHELSFIELD GROVE
MANCHESTER, M21 7SU

TEL.: +44 (0) 1618818515
E.MAIL.: info@marsanz.co.uk
www.marsanz.co.uk

DELEGACIONES EN ESPAÑA
BUREAUX REGIONAUX EN ESPAGNE
SPANISH BRANCHES

BARCELONA

POLIGONO INDUSTRIAL MOLI D'EN XECH
Calle Barneda, Nº 17 nave 25
Frente Rio Ripoll
08291 - RIPOLLET

TEL.: 93 231 34 75
FAX.: 93 231 35 47
E.MAIL.: barcelona@marsanz.es

SEVILLA

AVDA. DEL PARSÍ
POL.IND. MINI PARSÍ, NAVE 9
41016 SEVILLA

TEL.: 95 451 12 45
FAX.: 95 425 85 09
E.MAIL.: andalucia@marsanz.es

ALICANTE

C/ CAMPELLO, 13
POL.IND. LA CALA
03509 FINESTRAT - ALICANTE

TEL.: 96 680 27 04
FAX.: 96 683 07 96
E.MAIL.: levante@marsanz.es

DISTRIBUIDO POR

DISTRIBUÉ PAR

DISTRIBUTED BY



**WYPOSAŻENIE SKLEPÓW
I MAGAZYNÓW**

Poznań
60-478 Poznań
ul. Lutycka 105

tel. +48 61 847 28 32
tel./fax +48 61 841 15 73
tel. kom. 504 109 505
e-mail: poznan@mago-partner.com.pl

Warszawa
05-850 Ożarów Mazowiecki
ul. Poznańska 318

tel +48 22 725 76 36
tel./fax +48 22 725 76 67
tel. kom. 501 838 425
e-mail: warszawa@mago-partner.com.pl

Katowice
40-859 Katowice
ul. Pokoju 17

tel +48 32 298 03 83
tel./fax +48 32 298 04 83
tel. kom. 501 516 902
e-mail: katowice@mago-partner.com.pl

OD 2018 W ZGODNOŚCI Z ISO

